



DOP-B07

B07S(E)415 / B07S(E)515 / B07PS415 / B07PS515 Instruction Sheet

(1) Preface

Thank you for purchasing DELTA's DOP-B series. This instruction sheet will be helpful in the installation, wiring and inspection of Delta HMI. Before using the product, please read this instruction sheet to ensure correct use. You should thoroughly understand all safety precautions before proceeding with the installation, wiring and operation. Place this instruction sheet in a safe location for future reference. Please observe the following precautions:

- Install the product in a clean and dry location free from corrosive and inflammable gases or liquids.
- Ensure that all wiring instructions and recommendations are followed.
- Ensure that HMI is correctly connected to a ground. The grounding method must comply with the electrical standard of the country (Please refer to NFPA 70: National Electrical Code, 2005 Ed.).
- Do not disassemble HMI, modify or remove wiring when power is applied to HMI.
- Do not touch the power supply during operation. Otherwise, it may cause electric shock.

(2) Safety Precautions

Carefully note and observe the following safety precautions when receiving, inspecting, installing, operating, maintaining and troubleshooting. The following words, DANGER, WARNING and STOP are used to mark safety precautions when using the Delta's HMI product. Failure to observe these precautions may void the warranty!

Installation

DANGER

- Comply with quick start for installation. Otherwise it may cause equipment damage.
- Do not install the product in a location that is outside the stated specification for the HMI. Failure to observe this caution may result in electric shock, fire, or explosion.
- Do not install the product in a location where temperatures will exceed specification for the HMI. Failure to observe this caution may result in abnormal operation or damage the product.
- Please note that this equipment has obtained EMC registration for commercial use. In the event that it has been mistakenly sold or purchased, please exchange it for equipment certified for home use.
- Do not use this product as an alarm device for disaster early warning that may result in personal injury, equipment damage, or system emergency stop.

Wiring

DANGER

- Connect the ground terminals to a class-3 ground (Ground resistance should not exceed 100Ω). Improper grounding may result in communication error, electric shock or fire.

Operation

WARNING

- The users should use Delta Screen Editor software to perform editing in Delta's HMI product. To perform editing and confirming HMI programs without using Delta Screen Editor software in Delta's HMI product may result in abnormal operation.
- To prevent the personal injury and equipment damage, when designing HMI programs, please ensure that a communication error occurred between Delta's HMI product and the connecting controller or equipment will not result in system failure or malfunction.
- Please be sure to backup the screen data and HMI programs in case they are lost, accidentally deleted or worse.

STOP

- Do not modify wiring during operation. Otherwise it may result in electric shock or personal injury.
- Never use a hard or pointed object to hit or strike the screen as doing this may damage the screen and let the screen has not respond at all, and then cause HMI to work abnormally.

Maintenance and Inspection

STOP

- Do not touch any internal or exposed parts of the HMI as electrical shock may result.
- Do not remove operation panel while power is on. Otherwise electrical shock may result.
- Wait at least 10 minutes after power has been removed before touching any HMI terminals or performing any wiring and/or inspection as an electrical charge may still remain in the HMI with hazardous voltages even after power has been removed.
- Turn the power off before changing backup battery and check system settings after finishing change. (all data will be cleared after changing battery).
- Be sure the ventilation holes are not obstructed during operation. Otherwise malfunction may result due to bad ventilation or overheating troubles.

Wiring Method

WARNING

- Do not use a voltage that will exceed specification for the HMI. Failure to observe this caution may result in electric shock or fire.
- Remove the terminal block from the HMI before wiring.
- Insert only one wire into one terminal on the terminal block.
- If the wiring is in error, perform the wiring again with proper tools. Never use force to remove the terminals or wires. Otherwise, it may result in malfunction or damage.
- For the power line that forced to take out, ensure to check wiring again and restart.

Communication Wiring

WARNING

- Comply with communication wiring specification for wiring.
- Wiring length should comply with the stated specification for the HMI.
- Proper grounding to avoid bad communication quality.
- To avoid noise and interference, the communication cable, all power cables, and motor power cable should be placed in separate conduits.

(3) Pin Definition of Serial Communication

DOP-B07S(E)415 / DOP-B07PS415 Series

COM1 Port (Supports Flow Control)

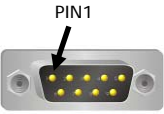
COM Port	PIN	Contact
	1	RS-232
	2	RXD
	3	TXD
	4	
	5	GND
	6	
	7	RTS
	8	CTS
	9	

Note: Blank = No Connection.

COM2 Port (Supports Flow Control)

COM Port	PIN	MODE1	MODE2	MODE3
		RS-232	RS-422	RS-485
	1		TXD+	D+
	2	RXD		
	3	TXD		
	4		RXD+	
	5	GND	GND	GND
	6		TXD-	D-
	7	RTS		
	8	CTS		
	9		RXD-	

Note1: Blank = No Connection.

Note2: When COM2 port is used for RS-232 flow control, i.e. RTS and CTS signals are used for flow control, COM3 port will become incapable of being used.

Note3: When COM2 port is used for RS-422 flow control, please refer to the following COM3 Port signals table for pin assignments. The signals, RTS+, CTS+, RTS- and CTS- shown in brackets are the signals used for flow control.

COM3 Port

COM Port	PIN	MODE1	MODE2	MODE3
		RS-232	RS-422	RS-485
	1		TXD+(RTS+)	D+
	2	RXD		
	3	TXD		
	4		RXD+(CTS+)	
	5	GND	GND	GND
	6		TXD-(RTS-)	D-
	7			
	8			
	9		RXD-(CTS-)	

Note1: Blank = No Connection.

Note2: When COM2 port is used for RS-422 flow control, please refer to the COM3 Port signals table above for pin assignments. The signals, RTS+, CTS+, RTS- and CTS- shown in brackets are the signals used for flow control.

DOP-B07S(E)515 / DOP-B07PS515 Series

COM1 Port (Supports Flow Control)

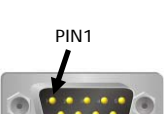
COM Port	PIN	Contact
	1	RS-232
	2	RXD
	3	TXD
	4	
	5	GND
	6	
	7	RTS
	8	CTS
	9	

Note: Blank = No Connection.

COM2 and COM3 Port

COM Port	PIN	MODE1		MODE2		MODE3	
		COM2	COM3	COM2	COM3	COM2	COM3
	1						
	2	RXD				RXD	
	3	TXD				TXD	
	4		D+		D+		RXD+
	5	GND		GND		GND	
	6			D-			TXD-
	7						
	8						
	9		D-		D-		RXD-

Note1: Blank = No Connection.

Note2: B05S111 / B07S(E)515/ B07PS515 series models do not support RS-422 flow control function.

Note3: COM3 is the extension port (COM2 and COM3 share one physical port).

DOP-B07E415 / DOP-B07E515 Ethernet Interface (LAN)



Ethernet Interface (LAN)	PIN	Contact
	1	TX+
	2	TX-
	3	RX+
	4	
	5	
	6	RX-
	7	
	8	

Note: Blank = No Connection.

(4) Parts Names

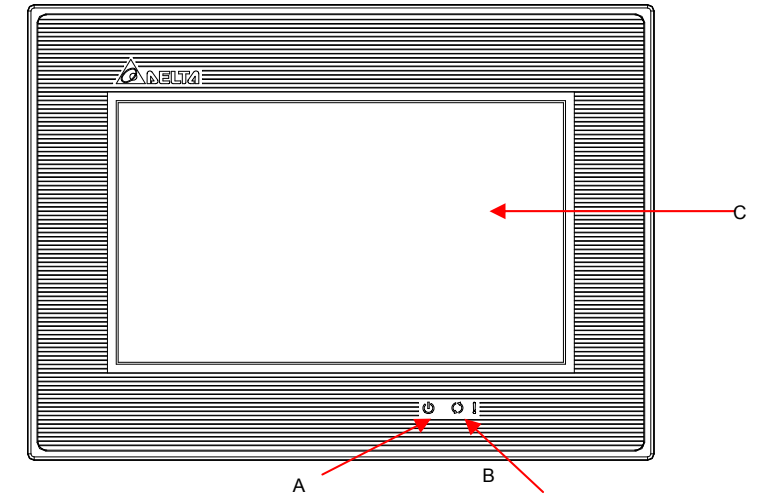
DOP-B07S(E)415 / DOP-B07PS415 (Front View)



A	 : Power LED Indicator Lights in green when HMI works normally.
C	 : Operation LED Indicator (Blue) ^(Note1) The operation LED indicator blinks in blue when either the communication is carried out or the data is accessing (please refer to the "Note1" below for explanation).
D	 : Alarm LED Indicator (Red) The alarm LED indicator blinks in red when one of the alarms is on.
D	Touch Screen / Display
<p>NOTE</p> <p>1. The definition of the operation LED indicator (Blue) can be determined by the users freely.</p>	

DOP-B07S(E)415 / DOP-B07PS415 (Rear View)

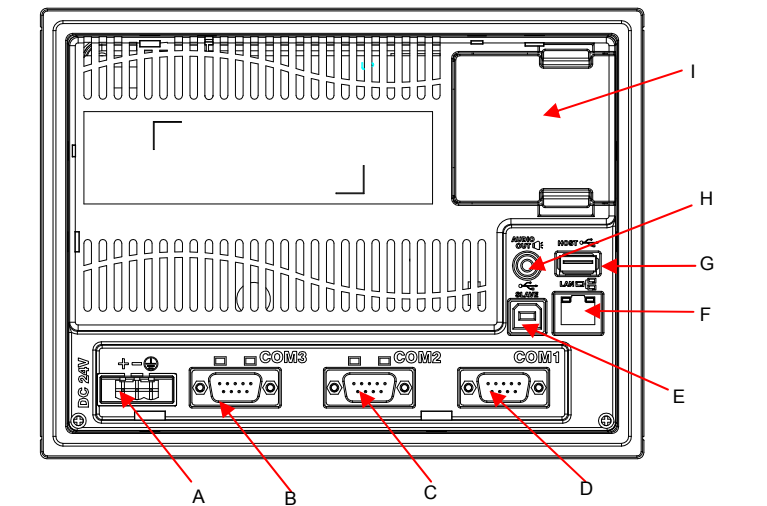

A	Power Input Terminal	F	Ethernet Interface (LAN)
B	COM3 (It is provided with two LED indicators to indicate that HMI is in Read or Write status during the communication process.)	G	USB Host
C	COM2 (It is provided with two LED indicators to indicate that HMI is in Read or Write status during the communication process.)	H	Audio Output Interface
D	COM1	I	Memory Card Slot / Battery
E	USB Slave	-	-

DOP-B07S(E)515 / DOP-B07PS515 (Front View)

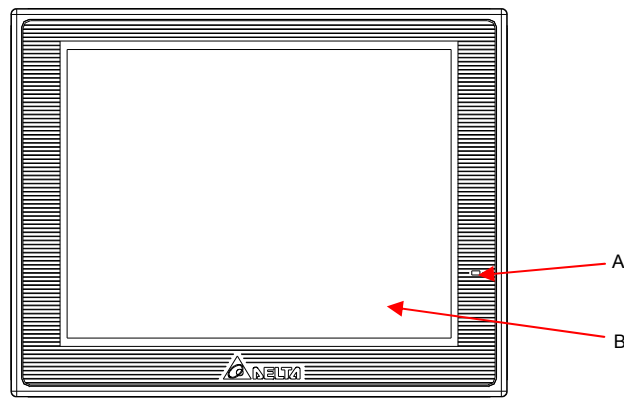

- A Power LED Indicator (Lights in green when HMI works normally.)
- B Touch Screen / Display

DOP-B07S(E)515 / DOP-B07PS515 (Rear View)

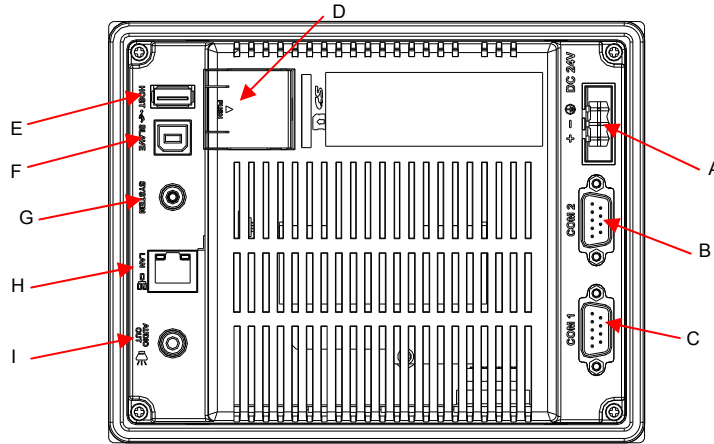

- | | | | |
|---|---|---|--------------------------|
| A | Power Input Terminal | F | USB Slave |
| B | COM2 (can be extended to COM3 ^(Note 1)) | G | System Key |
| C | COM1 | H | Ethernet Interface (LAN) |
| D | Memory Card Slot / Battery Cover | I | Audio Output Interface |
| E | USB Host | - | - |

NOTE

1. For the setting method, please refer to the pin definition of serial communication.

(5) Dimensions

DOP-B07S(E)415 / DOP-B07PS415

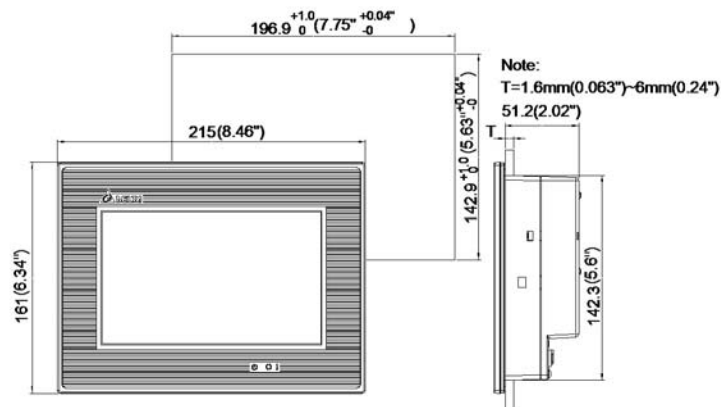

Units : mm (inches)

DOP-B07S(E)515 / DOP-B07PS515

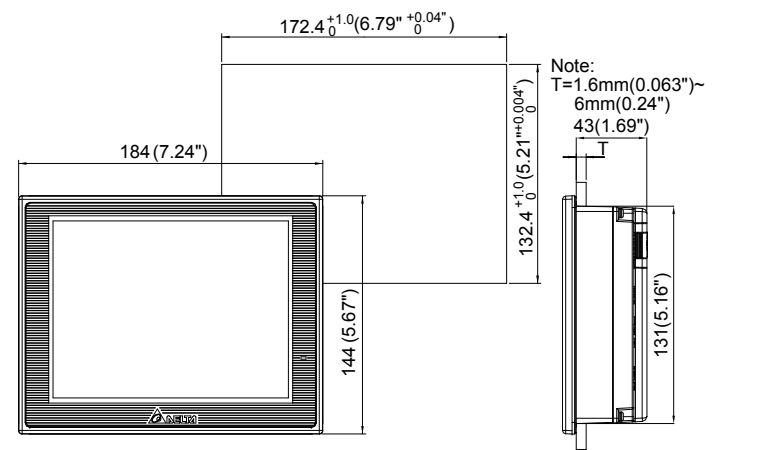

Units : mm (inches)

(6) Specifications

MODEL		DOP-B07 S415	DOP-B07 E415	DOP-B07 PS415	DOP-B07 S515	DOP-B07 E515	DOP-B07 PS515
LCD MODULE	Display Type	7" Widescreen TFT LCD (65536 colors)			7" TFT LCD (65536 colors)		
	Resolution	800 x 480 pixels			800 x 600 pixels		
	Backlight	LED Back Light (less than 20,000 hours half-life at 25°C) ^(Note 1)			LED Back Light (less than 10,000 hours half-life at 25°C) ^(Note 1)		
	Display Size	152.4 x 91.44mm			141 x 105.75mm		
Operation System		Delta Real Time OS					
MCU		32-bit RISC Micro-controller					
NOR Flash ROM		Flash ROM 128 MB (OS System: 30MB / Backup: 16MB / User Application: 82MB)					
SDRAM		64Mbytes					
Backup Memory		16Mbytes					
Sound Effect Output	Buzzer	Multi-Tone Frequency (2K ~ 4K Hz) / 85dB					
	AUX	N/A	Stereo output	N/A	N/A	Stereo output	N/A
Ethernet Interface		N/A	IEEE 802.3, IEEE 802.3u 10/100 Mbps auto-sensing (has built-in isolated power circuit ^(Note 3))	N/A	N/A	IEEE 802.3, IEEE 802.3u 10/100 Mbps auto-sensing (has built-in isolated power circuit ^(Note 3))	N/A
USB		1 USB Host ^(Note 2) Ver 1.1 / 1 USB Slave Ver 2.0					
Memory Card		SD Card (supports SDHC)					
Serial COM Port	COM1	RS-232 (supports hardware flow control)					
	COM2	RS-232 / RS-422 / RS-485	RS-232 / RS-422 / RS-485 (has built-in isolated power circuit ^(Note 3))	RS-232 / RS-422 / RS-485	RS-232 / RS-485	RS-232 / RS-485 (has built-in isolated power circuit ^(Note 3))	RS-232 / RS-485
	COM3	RS-232 / RS-422 / RS-485	RS-232 / RS-422 / RS-485 (has built-in isolated power circuit ^(Note 3))	RS-232 / RS-422 / RS-485	RS-422 / RS-485	RS-422 / RS-485 (has built-in isolated power circuit ^(Note 3))	RS-422 / RS-485
Function Key		N/A					
Perpetual Calendar (RTC)		Built-in					
Cooling Method		Natural air circulation					
Safety Approval		CE / UL ^(Note 4) / KCC ^(Note 4)					
Waterproof Degree		IP65 / NEMA4					
Operation Voltage ^(Note 5)		DC +24V (-10% ~ +15%) (please use isolated power supply)	DC +24V (-10% ~ +15%) (has built-in isolated power circuit ^(Note 3))	DC +24V (-10% ~ +15%) (please use isolated power supply)	DC +24V (-10% ~ +15%) (please use isolated power supply)	DC +24V (-10% ~ +15%) (has built-in isolated power circuit ^(Note 3))	DC +24V (-10% ~ +15%) (please use isolated power supply)
Voltage Endurance		AC500V for 1 minute (between charging (DC24V terminal) and FG terminals)					
Power Consumption ^(Note 5)		5W	7.5W	5W	7.68W		

Backup Battery	3V lithium battery CR2032 x 1	
Backup Battery Life	It depends on the temperature used and the conditions of usage, about 3 years or more at 25°C.	
Operation Temp.	0°C ~ 50°C	
Storage Temp.	-20°C ~ +60°C	
Ambient Humidity	10% ~ 90% RH [0 ~ 40°C], 10% ~ 55% RH [41 ~ 50°C] Pollution Degree 2	
Vibration	IEC 61131-2 compliant 5Hz ≤ f < 8.3Hz = Continuous: 3.5mm, 8.3Hz ≤ f ≤ 150Hz = Continuous: 1.0g	
Shock	IEC 60068-2-27 compliant 15g peak for 11 ms duration, X, Y, Z directions for 6 times	
Dimensions (W) x (H) x (D) mm	215 x 161 x 50	184 x 144 x 50
Panel Cutout (W) x (H) mm	196.9 x 142.9	172.4 x 132.4
Weight	Approx.970g	Approx.800g